

352i ATC Cabinet

Cabinets

Controllers

Signals

Signs

Software

Specialty



*Yellow rack not featured
in standard models*

Overview

McCain's 352i ATC Cabinet is an advanced transportation controller cabinet designed to increase driver and personnel safety, and provide state-of-the-art intersection control for any size intersection. Its revolutionary design combines the best of existing standards with the latest technology, while providing a viable migration path to low-voltage intersections. Compact, high-density (HD) components enhance operations while providing extra space for equipment or storage. Designed with safety as a paramount feature, the cabinet incorporates National Electrical Codes (NEC), or NFPA 70, by safeguarding users from accidental contact with components over 50V and housing the main circuit breaker at the point of power service entry.

Benefits

- Detects a dark approach through load current monitoring
- Manages up to 120 detector inputs and 32-channel outputs
- Offers increased functionality through compact high-density components
- Safeguards against accidental contact per NEC
- Enables migration to 48 VDC or ultra-low power LEDs
- Provides continuous monitoring of FTR and flasher status
- Allows for hot swappable output assembly

Product Description

The McCain 352i ATC Cabinet is designed around a standard, rack mount 332 cabinet shell, but the similarities to its predecessor end there. It relies on serial-based I/Os rather than the parallel I/Os and features high-density components that dramatically reduce assembly space requirements. In addition, it was designed to complement the operational capabilities of ATC controllers, so it easily handles up to 120 detector inputs and 32 channel outputs.

The cabinet's advanced safety features include load current monitoring, no exposed high-voltage per NEC, and the ability to keep the intersection in flash while replacing the output assemblies. The cabinet architecture supports 120 VAC while also providing a migration path to low-voltage 48 VDC environments.

The cabinet features a dual flasher/switch pack combination, no electrical leakage of switch packs, and hermetically sealed FTR's with an indicator reporting contact status.

352i ATC Cabinet

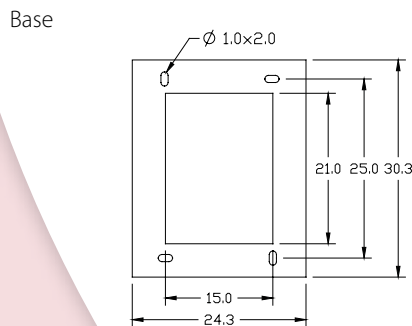
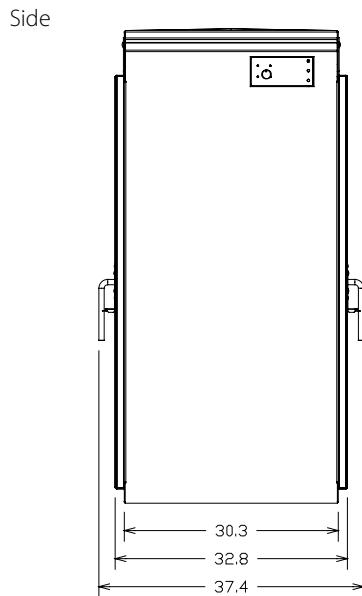
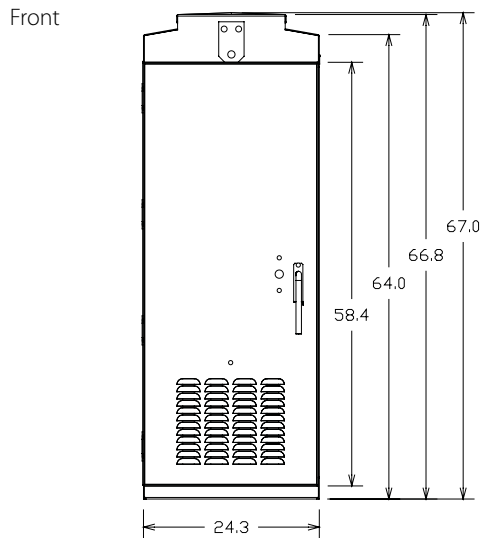

Dimensions rounded to the nearest 0.1"

Standard Features

- 8-phase, 4-pedestrian and 4-overlaps
- 48-channel detector, PPB, EVP, etc.
- 2-channel or 4-channel industry standard detection modules
- Model 2202 universal high-density switch pack / flasher (HDSPFU)
- 48 VDC airtight HDFTR, LED indicator reports contact status
- 48 VDC main contactor
- Programmable "Yellow/Red" or "All Red" flashes through the use of flash plugs

Assemblies

- Output assembly, 16-channel with a 2218 serial interface unit (SIU2) and a 2212 cabinet monitor unit (CMU2) socket
- Field output termination assembly (FOTA), 16-channel with (8) high-density flash transfer relay unit (HDFTR) sockets
- Input assembly (2), 24-channel with a 2218 (SIU2) socket
- Service assembly
- DC power / communication assembly
- Clean AC power assembly
- DC power supply assembly
- CMU2 auxiliary display unit (ADU)
- Police panel with signal "On/Off" and "Auto/Flash" switches
- Drawer assembly
- Fan panel assembly

General Specifications

| | |
|------------------|---|
| Dimensions: | 67" H x 24" W x 30" D (rounded to the nearest inch) |
| Material: | 5052-H32 aluminum, 0.125" thick |
| Finishes: | Anti-graffiti powder coat in standard colors (custom colors, natural finish, and anodized also available) |
| Access: | Front door (1), back doors (1), both full size |
| Latching System: | 3-point, choice of Corbin or Best locks |
| Handles: | 3/4" round, stainless steel with padlock hasp |
| Door Stops: | 90° ($\pm 10^\circ$), each door, top 90° and 180° ($\pm 10^\circ$), each door, bottom |
| Rack Assembly: | Removable 19" EIA rack |
| Ventilation: | Thermostatically controlled 100 CFM fan Louvered air intake in door, pleated filter |
| Mounting: | Base mounted |
| Shipping Weight: | 235 lbs without plug-ins or controller(s) |

Options

- 32-channel output assembly
- 32-channel FOTA
- Single 48-channel input assembly rack
- Field input termination assembly (FITA)
- Manual advance push button cable
- Cabinet LED light
- Fiber optic termination panel
- 3/4" x 16" anchor bolts for mounting (4)

To learn more about
McCain's Integrated Traffic
Solutions, please contact
info@mccain-inc.com or
call (760) 727-8100



2365 OAK RIDGE WAY // VISTA, CALIFORNIA 92081 // USA // WWW.MCCAIN-INC.COM

© 2013 McCain Inc. Updated 09/23/2013. McCain reserves the right to change product specifications without notice.
For the most up-to-date information, please contact McCain.